

# REINING PATTERN 7

All Reining Classes

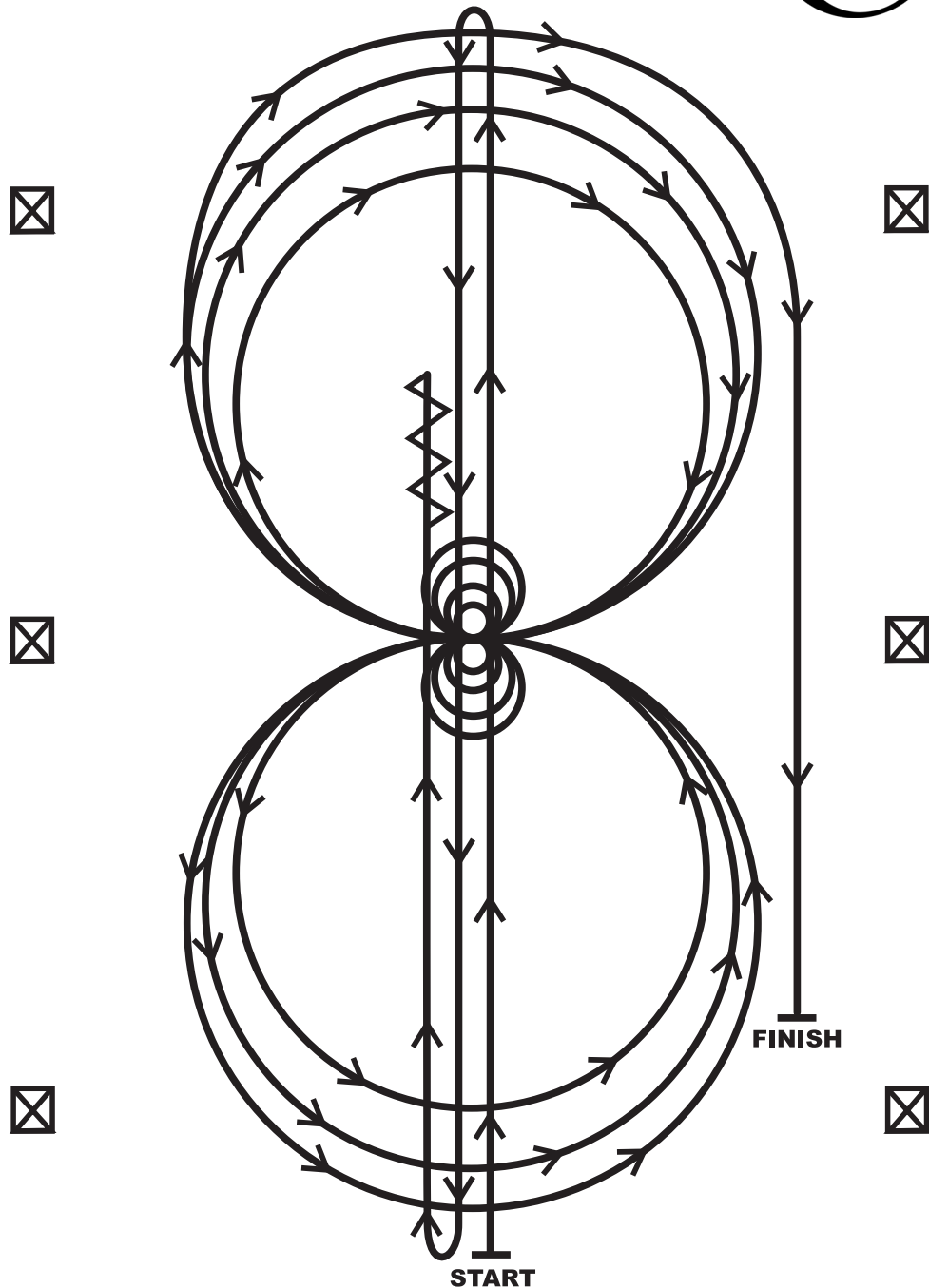

1. Run at speed to the far end of the arena past the end marker and do a left rollback—no hesitation.
2. Run to the opposite end of the arena past the end marker and do a right rollback—no hesitation.
3. Run past the center marker and do a sliding stop. Back up to the center of the arena or at least ten feet (three meters). Hesitate.
4. Complete four spins to the right. Hesitate.
5. Complete four and one-quarter spins to the left so that horse is facing left wall or fence. Hesitate.
6. Beginning on the right lead, complete three circles to the right: the first two circles large fast; the third circle small and slow. Change leads at the center of the arena.
7. Complete three circles to the left: the first two circles large fast; the third circle small and slow. Change leads at the center of the arena.
8. Begin a large circle to the right but do not close this circle. Run straight down the right side of the arena past the center marker and do a sliding stop at least twenty feet (six meters) from the wall or fence. Hesitate to demonstrate completion of the pattern.



**2026 CIRCLE G CLASSIC**  
 AQHA/VRH/ALL-BREED SHOW  
 RANCH TRAIL MEASUREMENTS

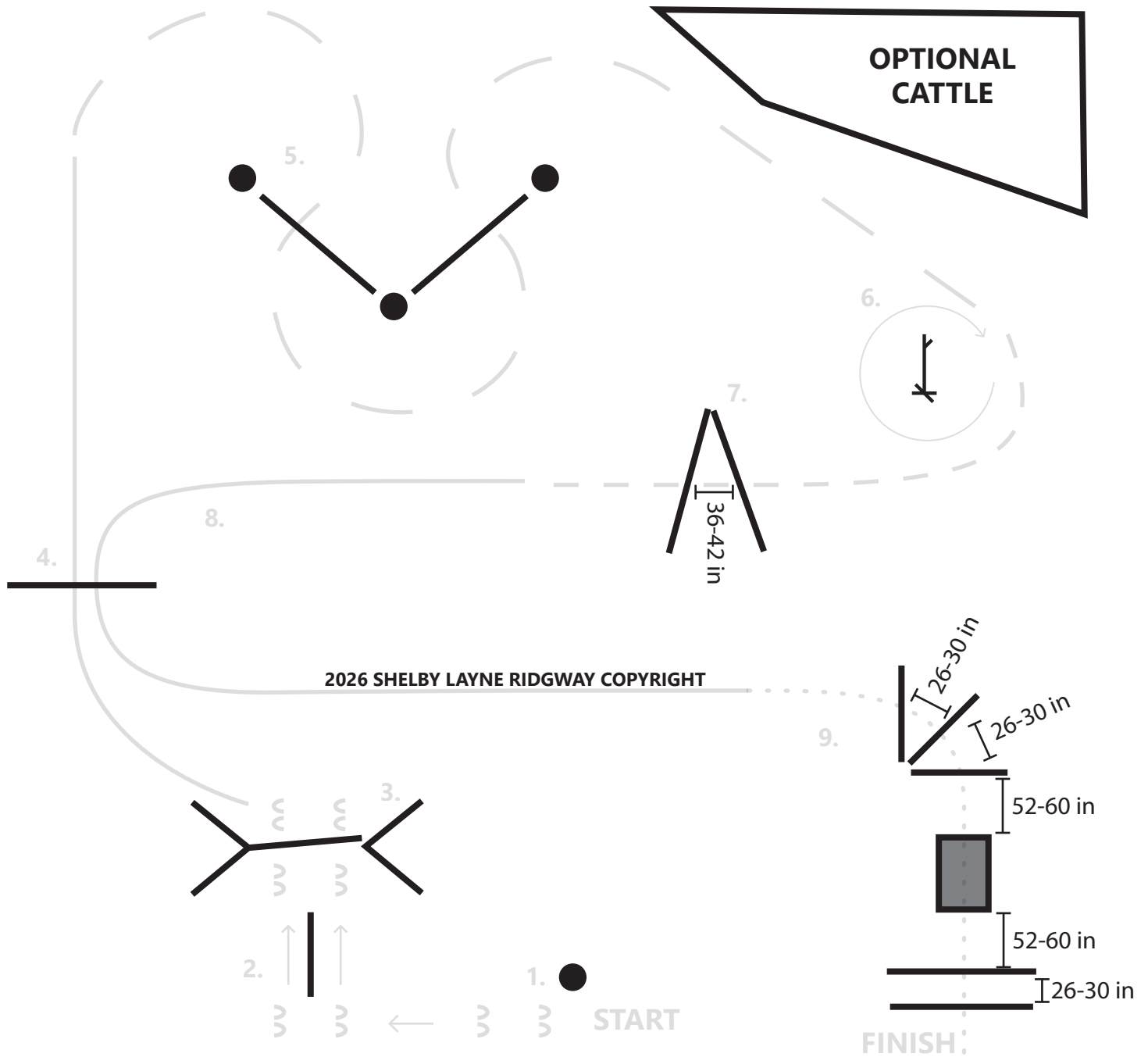

1. BACK
2. SIDEPASS LEFT
3. LEFT HAND GATE
4. RIGHT LEAD LOG
5. EXTEND TROT SERPENTINE UP TO DRAG

6. DRAG LOG TO THE RIGHT AT A WALK OR TROT (ALL YOUTH & L1/RK AMATEUR PICK UP OBJECT)
7. TROT OVER LOGS
8. LEFT LEAD LOG
9. WALK OVER BRIDGE AND LOGS



**2026 CIRCLE G CLASSIC**  
 AQHA/VRH/ALL-BREED SHOW  
 SMALL FRY WALK-TROT RANCH TRAIL

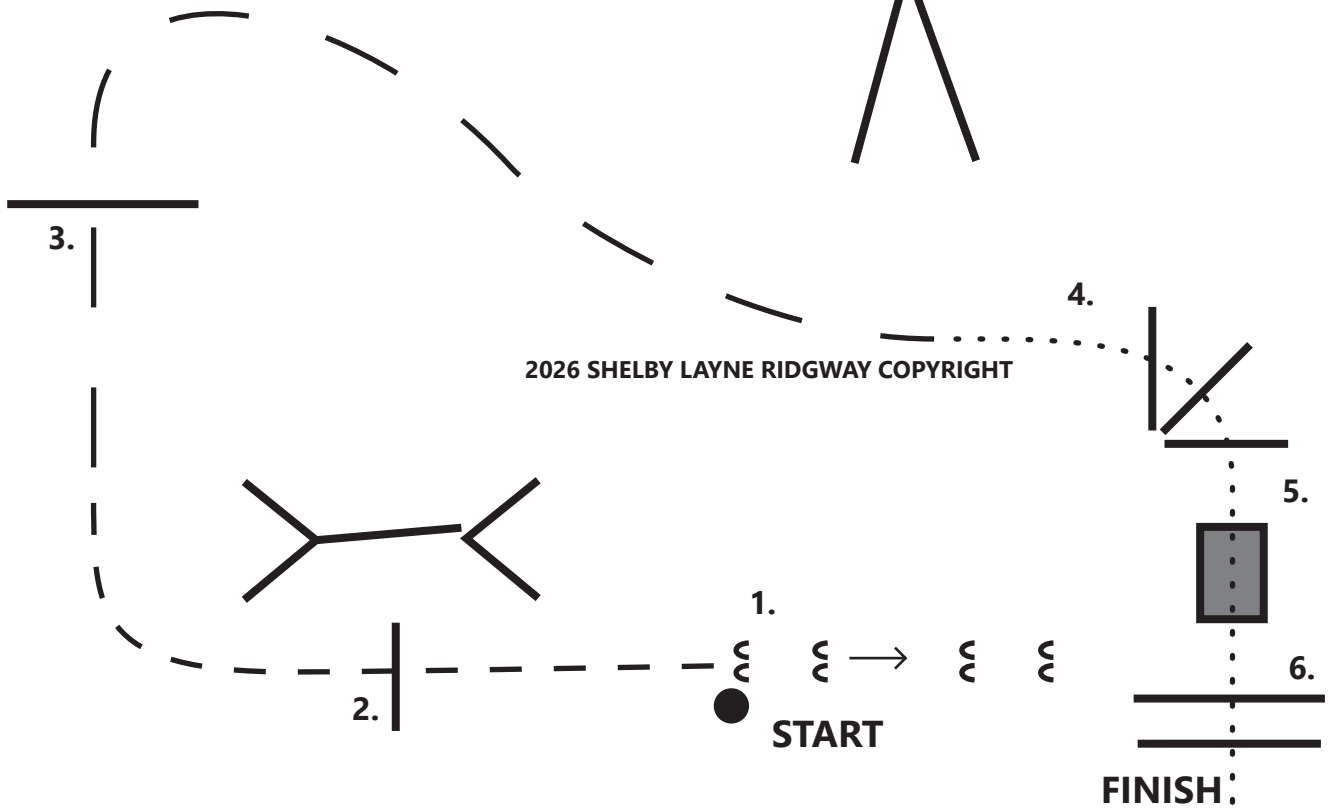
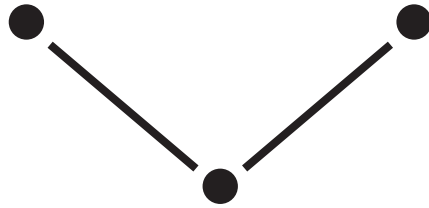
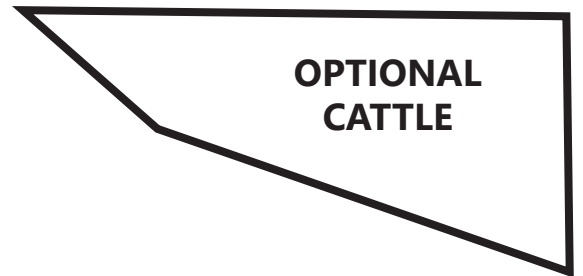

- 1. BACK
- 2. TROT LOG
- 3. EXTEND TROT LOG

- 4. WALK OVER LOGS
- 5. WALK OVER BRIDGE
- 6. WALK OVER LOGS



**2026 CIRCLE G CLASSIC**  
 AQHA/VRH/ALL-BREED SHOW  
 11 & OVER WALK-TROT RANCH TRAIL

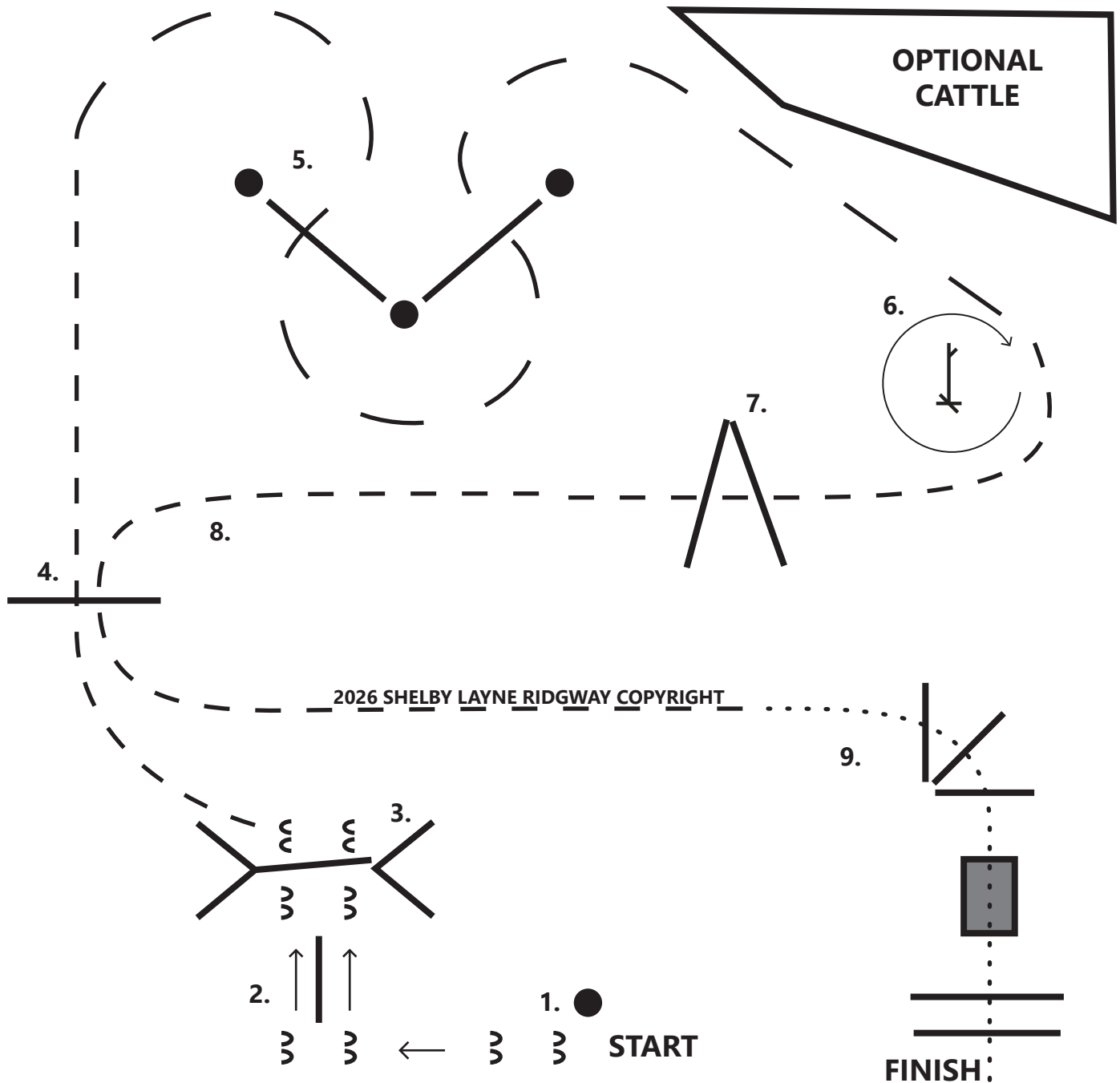

1. BACK
2. SIDEPASS LEFT
3. LEFT HAND GATE
4. TROT LOG
5. EXTEND TROT SERPENTINE UP TO DRAG

6. PICK UP OBJECT AND CARRY TO THE RIGHT AT A WALK OR TROT
7. TROT OVER V LOGS
8. TROT OVER SINGLE LOG
9. WALK OVER BRIDGE AND LOGS



**2026 CIRCLE G CLASSIC**  
 AQHA/VRH/ALL-BREED SHOW  
 ALL RANCH TRAIL CLASSES  
 (EXCEPT WALK-TROT)

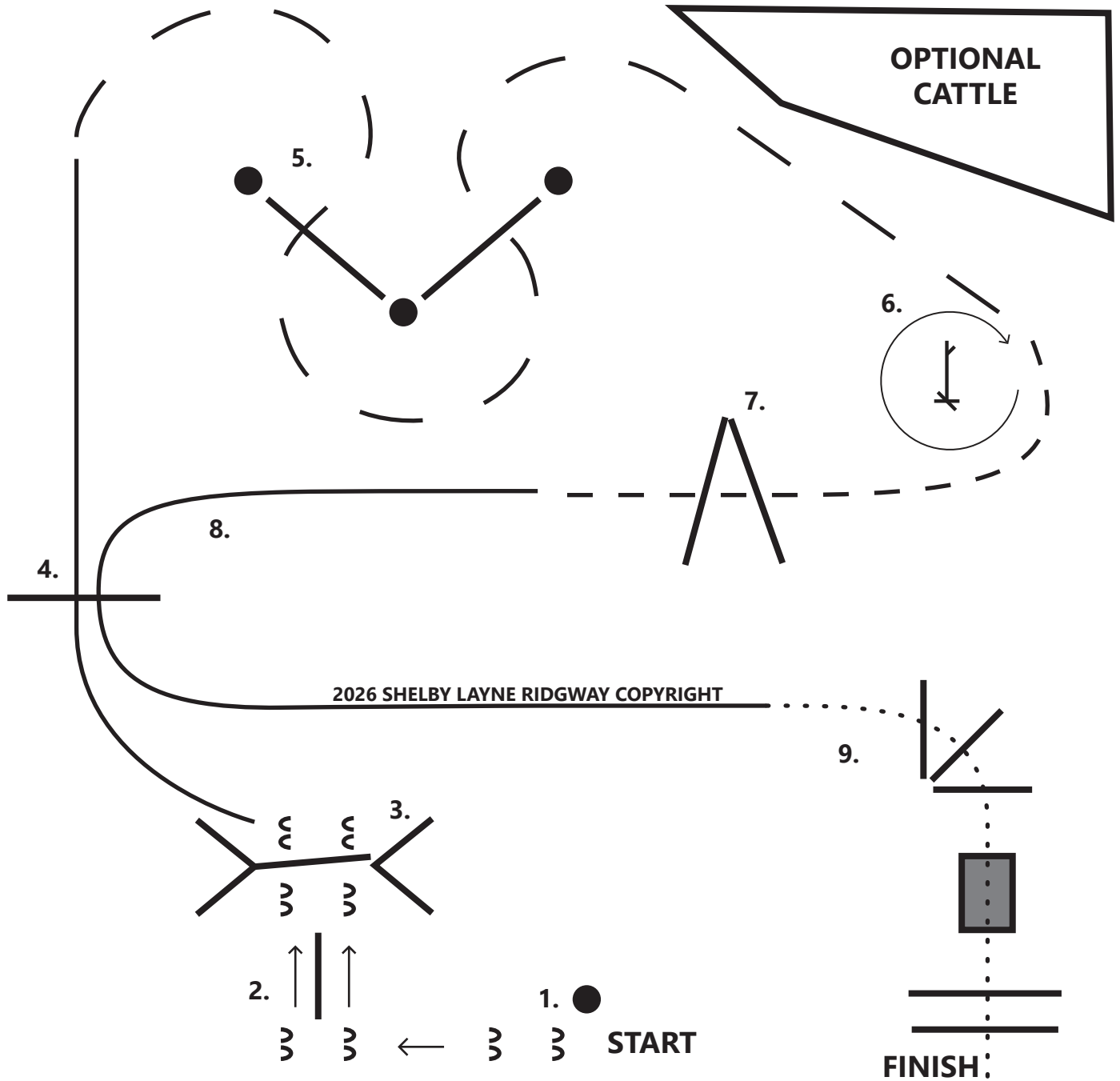

- 1. BACK
- 2. SIDEPASS LEFT
- 3. LEFT HAND GATE
- 4. RIGHT LEAD LOG
- 5. EXTEND TROT SERPENTINE UP TO DRAG

- 6. DRAG LOG TO THE RIGHT AT A WALK OR TROT (ALL YOUTH & L1/RK AMATEUR PICK UP OBJECT)
- 7. TROT OVER LOGS
- 8. LEFT LEAD LOG
- 9. WALK OVER BRIDGE AND LOGS

# VRH AND RHC RANCH REINING PATTERN 7

All Ranch Reining Classes

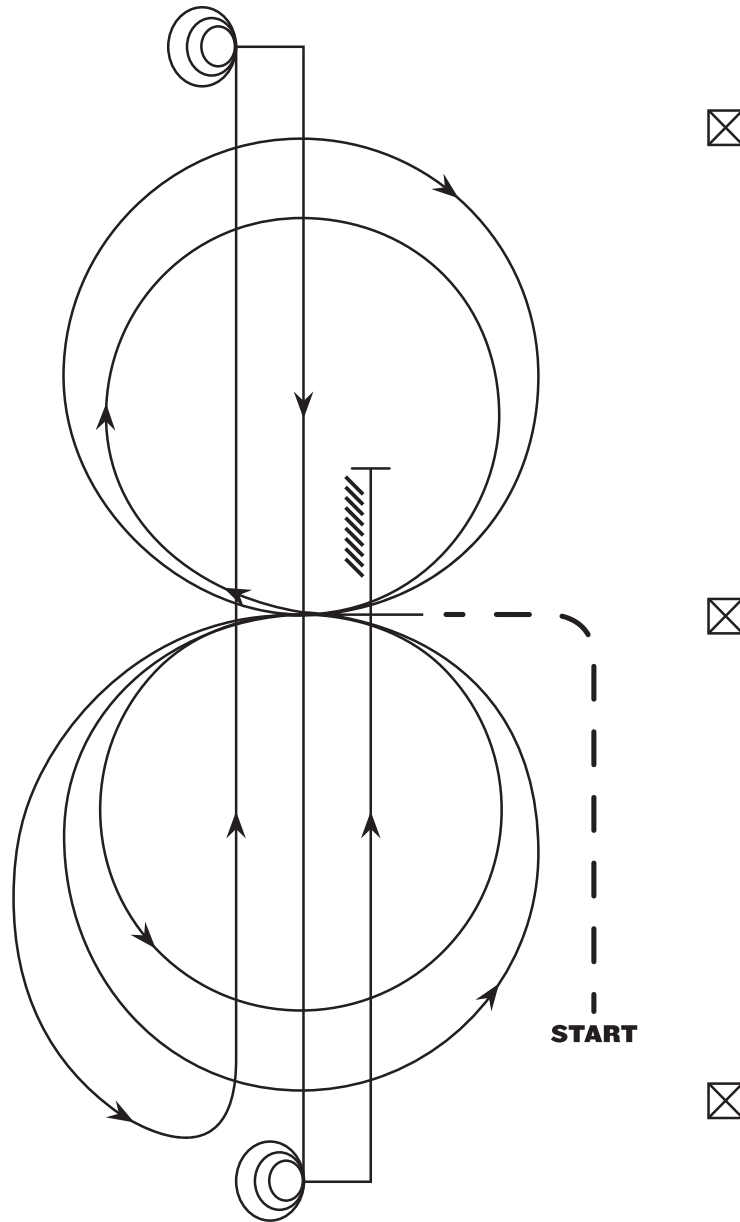

Mandatory Marker along Fence or Wall. Judge shall indicate with markers on arena wall or fence the center of pattern. Judge shall also place markers on fence or wall at least 50' from each end of the arena.

Ride pattern as follows: Trot to center of arena and stop or walk before departure. Start pattern facing toward judge.

1. Beginning on left lead, complete two circles to the left - the first one large and fast, the second one small and slow. Change leads at center of arena.
2. Complete two circles to the right - the first one large and fast, the second one small and slow. Change leads at center of arena.
3. Begin a circle to the left, but do not close this circle. Continuing around the end of arena, run up the center, past end marker, and do a sliding stop.
4. Complete 3 1/2 spins to the left.
5. Run down to other end of arena, past the end marker, and do a sliding stop.
6. Complete 3 1/2 spins to the right.
7. Run past the center marker and do a sliding stop. Back at least 10 feet. Hesitate to show completion pattern

WORKING COW HORSE PATTERN 11  
All Working Cow Horse, Box-Drive, & Boxing Classes

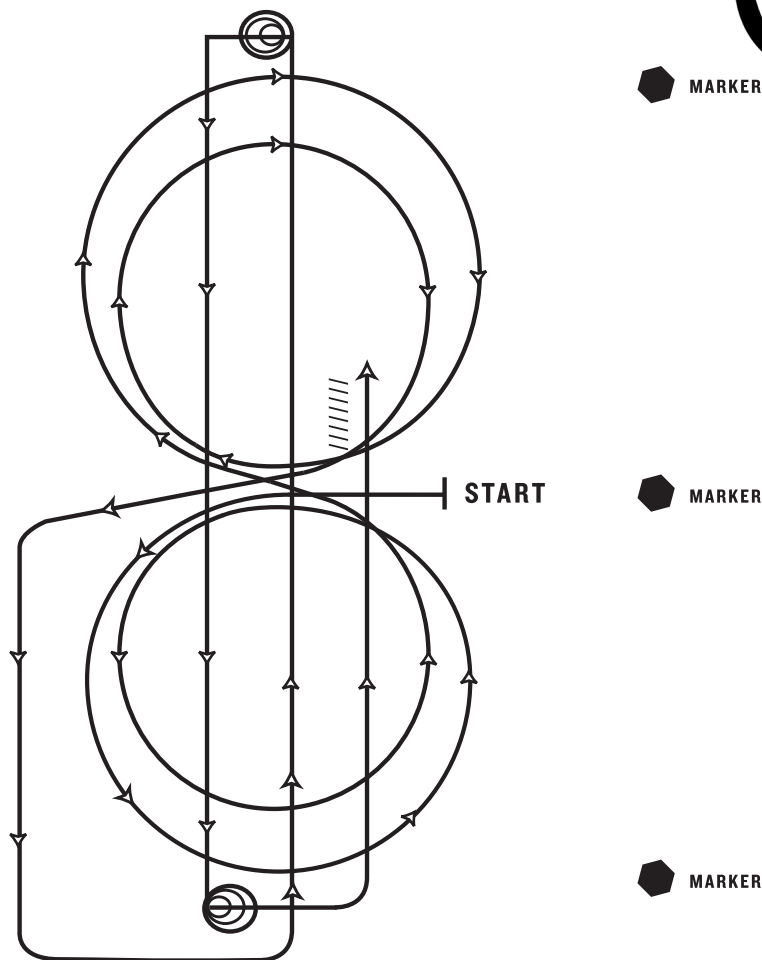

Trot to center of arena, stop. Start pattern facing towards judge

1. Beginning on the left lead, complete 2 circles to the left; the first circle large and fast, the second circle small and slow. Change leads at the center of the arena.
2. Complete 2 circles to the right; the first circle large and fast, the second circle small and slow. Change leads at the center of arena.
3. Continue around end of arena without breaking gait or changing leads, run down center of arena past end marker, and execute a square sliding stop.
4. Complete 3 1/2 spins to the left.
5. Run down center of arena past end maker, and execute a square sliding stop.
6. Complete 3 1/2 spins to the right.
7. Run down center of arena past center marker, and execute a square sliding stop. Back up at least 10 feet. Hesitate to complete pattern.

Pattern 11

- |                  |                      |
|------------------|----------------------|
| 1. Left circles  | 4. 3 1/2 left spins  |
| 2. Right circles | 5. Stop              |
| 3. Stop          | 6. 3 1/2 right spins |
|                  | 7. Stop and back up  |

This pattern may be used as a lope-in pattern; refer to SHW505.2.



**2026 CIRCLE G CLASSIC**  
AQHA/VRH/ALL-BREED SHOW  
SMALL FRY AND 11 & OVER WALK-TROT  
SHOWMANSHIP

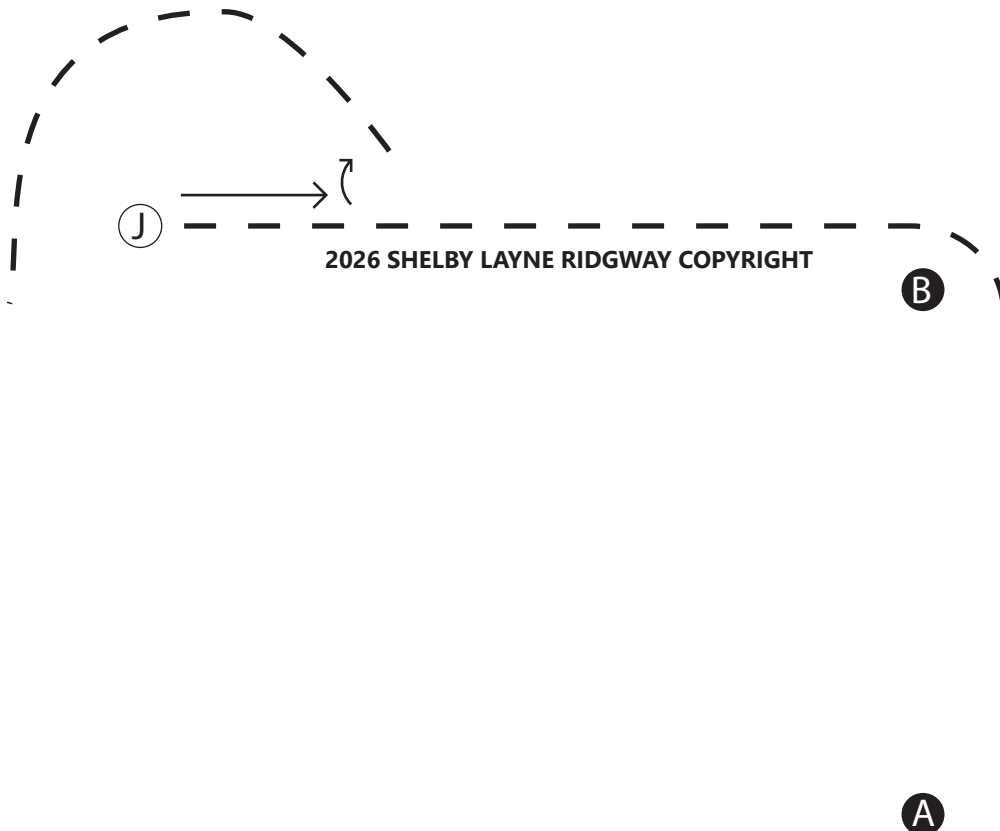

1. Walk halfway to B
2. Trot around B and up to judge
3. Set up for inspection
4. Inspection
5. Once dismissed, back six steps
6. Perform a 45 degree turn
7. Exit at a trot



**2026 CIRCLE G CLASSIC**  
AQHA/VRH/ALL-BREED SHOW  
ALL SHOWMANSHIP CLASSES  
(EXCEPT WALK-TROT)

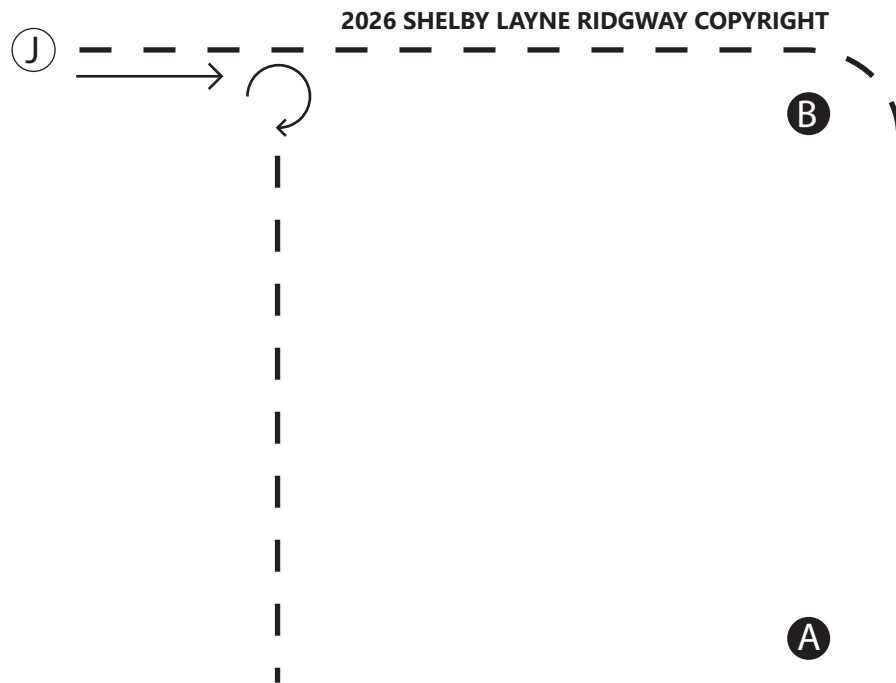

1. Walk halfway to B
2. Trot around B and up to judge
3. Set up for inspection
4. Inspection
5. Once dismissed, back six steps
6. Perform a 270 degree turn
7. Exit at a trot



**2026 CIRCLE G CLASSIC**  
AQHA/VRH/ALL-BREED SHOW  
SMALL FRY WALK-TROT HORSEMANSHIP

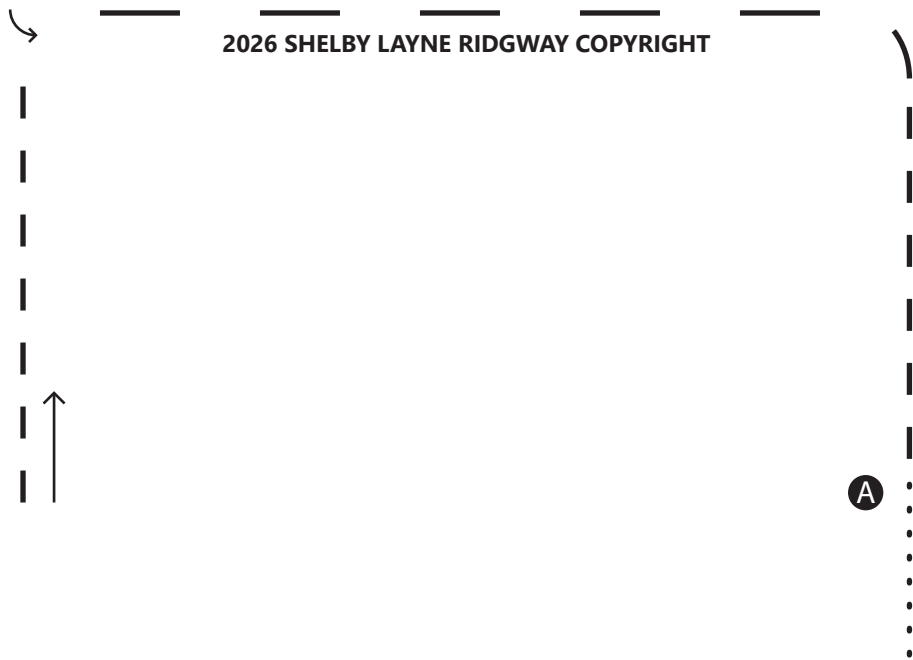

1. Walk to A
2. Trot
3. Extend Trot and stop
4. Execute a 90 to the left
5. Trot and stop when even with A
6. Back 6 steps

Note: the drawn description of this pattern is only intended for the general depiction of the pattern. Exhibitors should utilize the arena space to best exhibit their horse





**2026 CIRCLE G CLASSIC**  
AQHA/VRH/ALL-BREED SHOW  
ALL HORSEMANSHIP CLASSES  
(EXCEPT WALK-TROT)

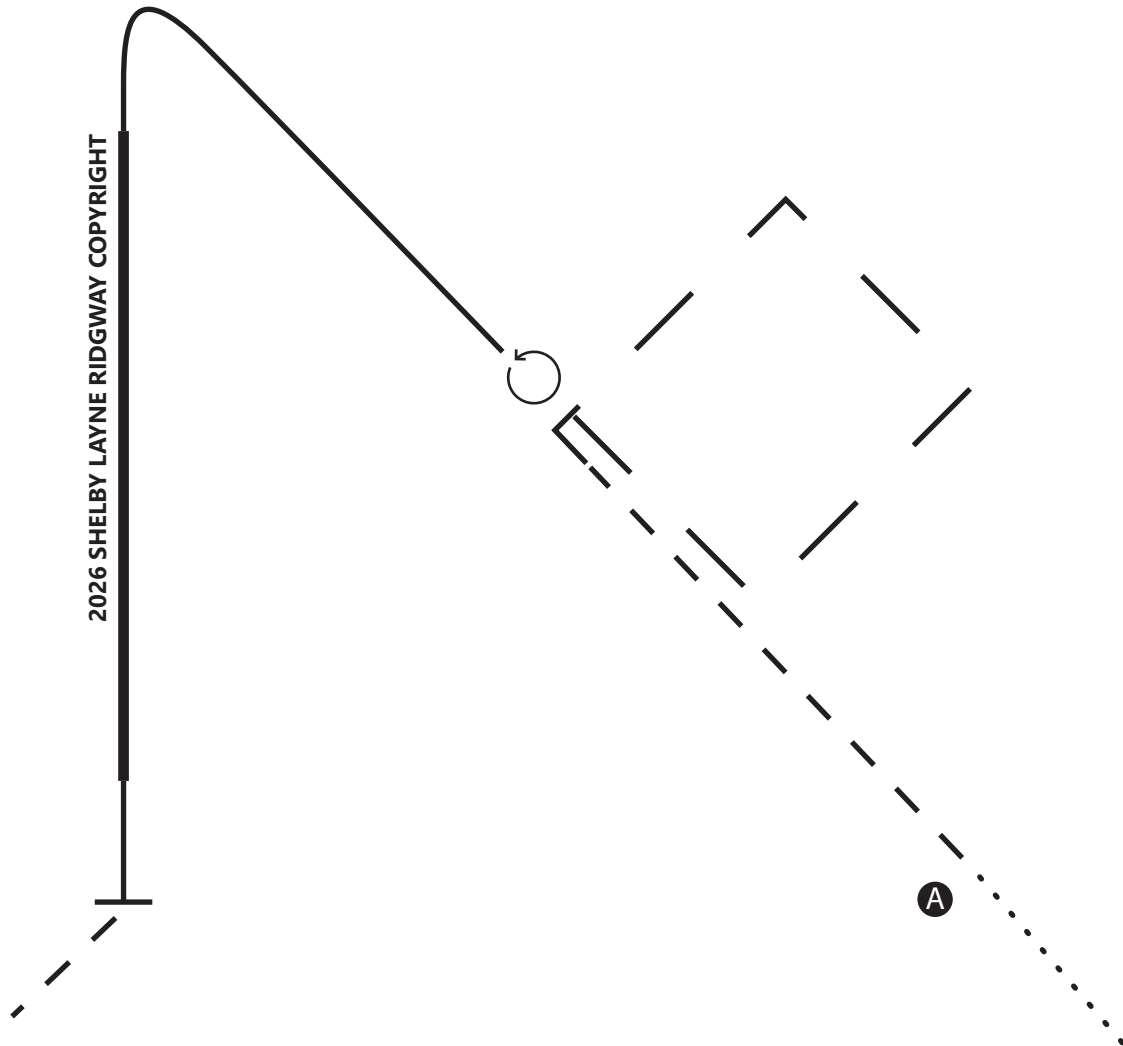

1. Walk to A
2. Trot
3. Extend Trot a box
4. Stop, 360 left
5. Left Lead
6. Build to an extended lope
7. Collect the lope
8. Stop when even with A, hesitate and exit at a trot

Note: the drawn description of this pattern is only intended for the general depiction of the pattern. Exhibitors should utilize the arena space to best exhibit their horse



# RANCH RIDING - PATTERN 15

2026 CIRCLE G CLASSIC  
ALL RANCH RIDING (EXCEPT WALK-TROT CLASSES)

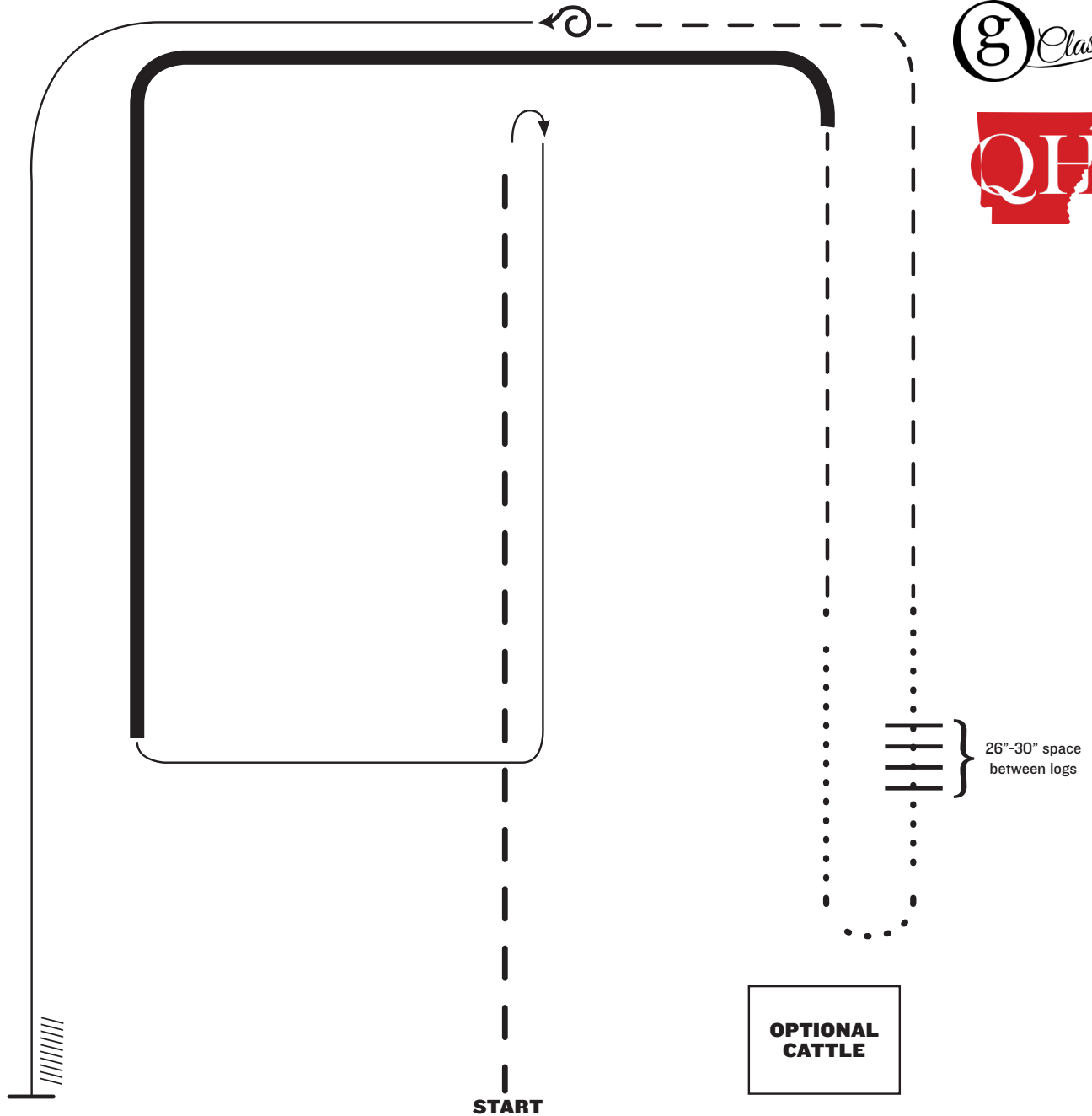

1. Extended trot
2. Stop, rollback right
3. Lope right lead
4. Extended lope (right lead)
5. Trot
6. Walk
7. Walk over logs
8. Walk
9. Trot
10. Stop, 360 left
11. Lope left lead
12. Stop and back

Note: The drawn description of this pattern is only intended for the general depiction of the pattern. Exhibitors should utilize the arena space to best exhibit their horses.